

iDRN-FP
FREQUENCY/PULSE INPUT

General Description:

The iDRN Series of DIN rail-mountable signal conditioners are available for Thermocouple, RTD, Strain, Process, AC Voltage, AC Current and Pulse/Totalizer input types. The factory calibrated signal conditioners are ideal for all process and power monitoring applications, they feature 3-way isolation, high accuracy input, programmable outputs, and are excellent front end interfaces for programmable logic controllers or data acquisition systems. For maximum user configurability the signal conditioners allow complete input-output scaling via a RS-232 connection to any PC or PLC.

Software Description:

The signal conditioner configuration program is a MS DOS/Windows program (this manual is for the Windows version). It is designed especially for the iDRN Series Signal Conditioner. This program will run on any PC with Windows application and will start automatically.

Free Serial Communication software and ActiveX Controls are on the CD-ROM enclosed with this shipment. To download the latest software release (or request a free CD-ROM) please go to: www.newportUS.com/software

What You need:

- Your choice of the signal conditioner
- IBM PC or compatible
- Windows software 3.1 or higher, or Windows 95/98
- RJ12 connector with telephone cable
- Adapter (DB9 or DB25 to RJ12)

Setting up your System

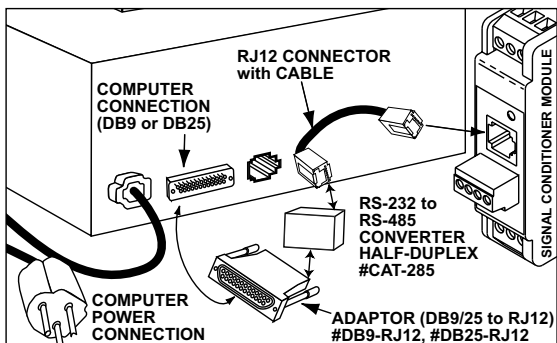

INPUT TYPE:

Min. Low level signal input (magnetic pickups) : From 0 mV to 120 mV
Open Collector NPN (Use software to set: 3 KΩ pull up to 5V): Max. current source = 1.66 mA
Open Collector PNP (Use software to set: 1KΩ pull down to RTN): Max. current sink = 12.5 mA

TTL/CMOS Input: (Use software to set: no pull up/down).
Low <= 0.8 V , High >= 3.5 V (For Input: 0.2 Hz to 16 KHz)
Low <= 0.8 V , High >= 12 V (For Input: 0.2 Hz to 50 KHz)
NAMUR Sensors (Use software to set: 1KΩ pull down to RTN and 8.2V Excitation.)

For measuring a low level signal riding on top of a large DC signal, connect a 0.1 uF capacitor. See Detail. Use software to set 1KΩ pull down to RTN.

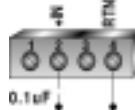

OPERATING MODES:

Frequency: Range = 0.2 Hz to 50 KHz
Max. Input Frequency: 30 KHz. for Input Level: 0-5 V
Max. Input Frequency: 50 KHz. for Input Level: 0-12 V

FREQUENCY

0 to 9.99999 Hz
10 to 99.9999 Hz
100 to 999.999 Hz
1000 to 9999.99 Hz
10000 to 50000.0 Hz
0 to 50000 Hz

RESOLUTION

0.00001 Hz
0.0001 Hz
0.001 Hz
0.01 Hz
0.1 Hz
1 Hz

Totalize with Reset: Range = 0 to 999999*, if reading is larger than 999999, then reading is converted to floating point number, i.e. 9.99E9 (maximum).

Max. Input Frequency: 30 KHz. for Input Level: 0-5 V
Max. Input Frequency: 50 KHz. for Input Level: 0-12 V

A-B Totalize (Reset input used as +A input): Range = -99999 to 999999*, if reading is larger than 999999, then reading is converted to floating point number, i.e. -9.99E9 (minimum), 9.99E9 (maximum).

Max. Input Frequency: 30 KHz. for Input Level: 0-5 V
Max. Input Frequency: 25 KHz. for Input Level: 0-12 V

Quadrature (Reset input used as second input): Range = -99999 to 999999*, if reading is larger than 999999, then reading is converted to floating point number, i.e. -9.99E9 (minimum), 9.99E9 (maximum).

Max. Input Frequency: 30 KHz. for Input Level: 0-5 V
Max. Input Frequency: 25 KHz. for Input Level: 0-12 V

* Resolution is 1 count.

ISOLATION:

Dielectric strength per 1 minute test based on EN 61010 for 50 Vdc or Vrms working voltage.
Three way Isolation:

- Power to Signal Input: 1800V Peak
- Power to Analog Output/Communication: 1800V Peak
- Signal Input to Analog Output/Communication: 1400V

COMMON MODE REJECTION:

100 dB

INPUT IMPEDANCE:

Input: 1MΩ to +EXC Reset: 100K to +5V

INPUT OVER-VOLTAGE PROTECTION:

With 1K pull down: 14V With 3K pull up: 20V
Without pull up/down: 60V

EXCITATION:

5, 8.2 or 12.5V at 25mA, programmable

ACCURACY AT 25 °C:

± 0.1% of Full scale Crystal time base accuracy: ± 50 ppm

TEMPERATURE STABILITY:

± 50 ppm/°C typical Time base stability: ± 1ppm/°C

STEP RESPONSE FOR RS232 OUTPUT:

0.1 second to 99% of the final value
(Filter time constant = 0, Gate time = 0.05 Sec)

RESPONSE TIME:

To verify the response time, check the carriage return <CR>, it will be sent at the end of the response. You can send another command after you receive the <CR>.

i.e. **send:** *X01 **response:** X01<DATA><CR>

Note: Only for reading (X01 command).

Frequency mode: response time is controlled by the gate time. If gate time is increased then response time is longer.

Other modes: response time is not controlled by the gate time.

ANALOG OUTPUT STEP RESPONSE TIME:

2 Seconds to 99% of the final value

WARM UP TO RATED ACCURACY:

30 minutes

ANALOG OUTPUT SIGNAL TYPE:

Voltage: 0-10 Volt, maximum current 10mA

Current: 0-20 mA or 4-20 mA, maximum compliance voltage 10 Volts (maximum loop resistance 500Ω)

ANALOG OUTPUT LINEARITY:

0.1% of FS

INPUT POWER:

10 to 32 Volt DC

POWER CONSUMPTION:

3 Watts (125mA at 24V DC)

OPERATING AMBIENT:

-5 to +55 °C

STORAGE TEMPERATURE:

-40 to +85 °C

RELATIVE HUMIDITY:

90% at 40 °C
non-condensing

DIMENSIONS:

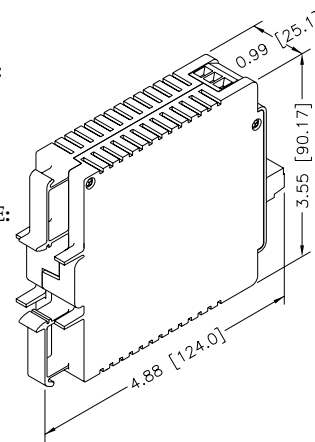

Introduction:

The frequency/pulse signal conditioners are high performance instruments which operates in 4 different modes. Input can be programmed to read different signal sources including low level pulse, open collector and TTL/CMOS signals. Key features are: programmable excitation and input; operates as a rate meter, totalizer with reset, A-B totalize and Quadrature; scalable analog output and a simple RS232 interface for scaling analog output and range selection. The RS232 interface may also be used for digital transmission of the input signal to a computer or a PLC. Additional features include three way isolation between DC power, signal input and analog output/RS232.

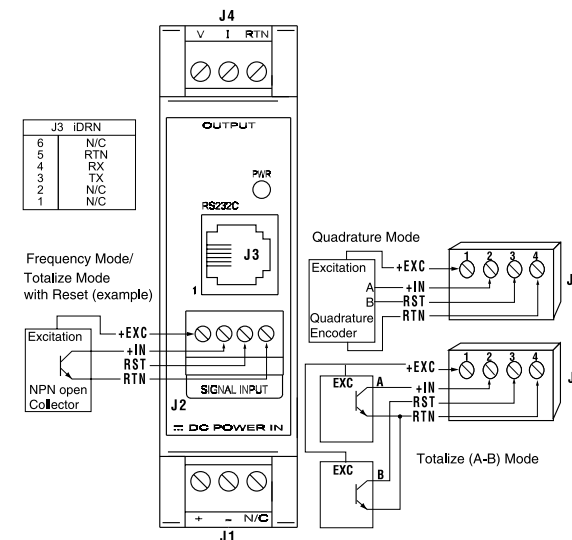

Operation:

Note: When connecting a pulse signal, ensure that the input signal voltage is less than or equal to the rating. The unit may be damaged if the input voltage exceeds the maximum rating.

Power Input and Analog Output Setup:

To connect the signal input proceed as follows:

1. Connect a DC power supply with an output voltage between 10 to 32 Vdc to the signal conditioner (J1).

Note: If power supply used has current limiting, it may not be able to power the signal conditioners if the available output voltage is around 10 V, since the peak current may reach 1 to 5 Amps for a few milliseconds.

2. Ensure that if the selected mode or signal source is different from the default then change them using serial communication explained later in this manual.

5

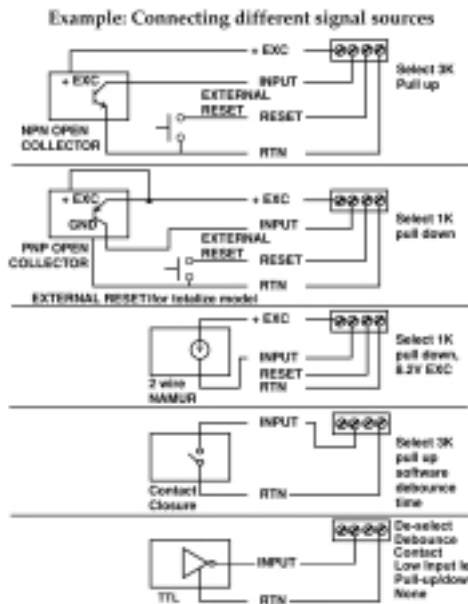

3. Connect the signal input to screw terminal, and ensure that the screws are tight

4. To view/change the scaling that relates the analog output to signal input: connect the RS232 output of the signal conditioner to an available serial port of a computer. The cable and the DB9 or DB25 connectors are available as an option.

5. Turn on the computer, start Windows 3.0 or higher and run the Signal Conditioner Configuration Setup Program.

6. Start the configuration program, you need to indicate which serial port is to be used for serial communication by checking the appropriate check box on the opening menu.

Note: It is not necessary to know the serial communication protocol. i.e. baud rate, parity, 7/8 data bit and stop bit; the program will determine this information automatically. However, it is good practice to mark the protocols used on the signal conditioner label if different from default.

7. Once the program starts it will automatically detect the signal conditioner configuration and will display a window of available options. To view the signal input click on the display on/off.

8. To change analog output scaling choose analog output scaling and enter the desired values.

9. Once the custom scaling is finished, **ensure that Send Configuration is clicked**, otherwise the changes will not take effect.

10. The input/output scaling may be fine tuned, while both communication and analog output are active. You may make a change to the analog output in the configuration program, and watch the DVM connected to analog output of the signal conditioner follow the new settings.

6

11. You may save or print a particular configuration by selecting the file menu. It's always a good practice to both print and save the scaling of each signal conditioner.

12. If the program is not able to establish communication then an error message is displayed. This happens either when the wrong serial port is specified or when the cable is disconnected.

13. The procedure to disable Continuous Mode and change the iDRN to Command Mode is as follows:

Using HyperTerminal, or any serial communication program, type: **Ctrl + S**

To change the device to Command Mode, type: **^AE**

To change the Bus Format Register, type: ***W0814**

To reset the device, type: ***Z01**

Cycle power to the unit.

Modbus Register Definition

Reg. #	Read Function	Write Function	# of byte
1	Input Range	Input Range	1
2	Input/Output Config.	Input/Output Conf.	1
3	Decimal Point	Decimal Point	1
4	Filter Time Constant	Filter Time Constant	1
5	Reading/Output Scale	Not supported	3
6	Reading/Output Offset	Not supported	3
7	Comm. Parameters	Comm. Parameters	1
8	Comm. Bus Format	Comm. Bus Format	1
9	Comm. Data Format	Comm. Data Format	1
A	Comm. Device Addr.	Comm. Device Addr.	1
B	Comm. Recog. Char.	Comm. Recog. Addr.	1
C	Unit of measure	Not supported	3
D	Gate Time	Gate Time	1
E	Debounce Time	Debounce Time	1
F	Transmit Time	Transmit Time	2
10	Main Value	Hard Reset	3
11	Peak Value	Reset Peak	1
12	Valley Value	Reset Valley	1
13	Not Supported	M.S. bytes Output Scale	2
14	Not Supported	L.S. byte Output Scale	1
15	Not Supported	M.S. bytes Output Offset	1
16	Not Supported	L.S. byte Output Offset	2

Note:

- Main, Peak, Valley value: 4 bytes will send from the unit
 - Highest byte always 00h.
 - 2nd Highest byte: (MSB is sign (1=negative, 0=positive), next 3 bits are number of decimal points).
 - Low nibble of second byte, and lowest 2 bytes are the value.
 - The decimal point register has to set to: 1, 2, 3, or 4.
- Bus Format: Bit 5 1/0 = Modbus/Newport
- Output Scale/Offset Write:

Due to write single only, two write operation is needed to write scale/offset, and to make it effective it needs to follow with Hard Reset command.
- To configure to Newport protocol, set bit 5 of Bus Format to low and follow with Hard Reset command.

WARNING: These products are not designed for use in, and should not be used for, patient-connected applications.



This device is marked with the international caution symbol. It is important to read the Setup Guide before installing or commissioning this device, as the guide contains important information relating to safety and EMC.

It is the policy of NEWPORT to comply with all worldwide safety and EMC/EMI regulations that apply. NEWPORT is constantly pursuing certification of its products to the European New Approach Directives. NEWPORT will add the CE mark to every appropriate device upon certification.

The information contained in this document is believed to be correct, but NEWPORT Electronics, Inc. accepts no liability for any errors it contains, and reserves the right to alter specifications without notice.

PATENT NOTICE: This product is covered by one or more of the following patents: U.S. Pat. No. Des. 336,895, 5,274,577/ Canada 2052599, 2052600/ Italy 1249456, 1250938/ France Brevet No. 91 12756/ Spain 2039150, 2048066/ UK Patent No. GB2 249 837, GB2 248 954/ Germany DE 41 34398 C2.

TRADEMARK NOTICE:

NEWPORT, **NEWPORT**, **INFINITY**, **newportUS.com** and **INFINITY** are trademarks of NEWPORT Electronics, Inc.

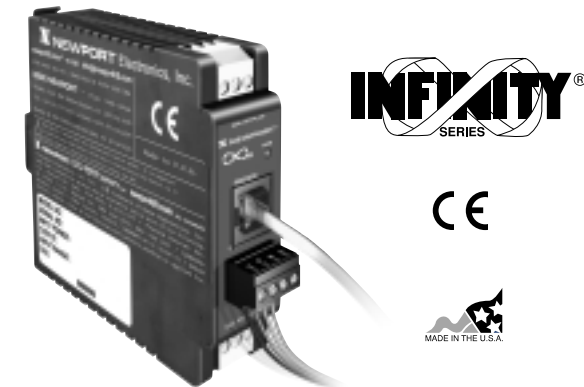

iDRN-FP

Frequency/Pulse Signal Conditioner

For immediate technical or application assistance please call:

1-800-6397678
1-800-NEWPORT

Newport Electronics, Inc.
2229 South Yale Street • Santa Ana, CA • 92704 • U.S.A.
TEL: (714) 540-4914 • FAX: (203) 968-7311
Toll Free: 1-800-639-7678 • www.newportUS.com • e-mail: info@newportUS.com
ISO 9001 Certified

Newport Technologies, Inc.
976 Bergar • Laval (Quebec) • H7L 5A1 • Canada
TEL: (514) 335-3183 • FAX: (514) 856-6886
Toll Free: 1-800-639-7678 • www.newport.ca • e-mail: info@newport.ca

Newport Electronics, Ltd.
One Omega Drive • River Bend Technology Centre
Northbank, Irlam • Manchester M44 5BD • United Kingdom
Tel: +44 161 777 6611 • FAX: +44 161 777 6622
Toll Free: 0800 488 488 • www.newportuk.co.uk • e-mail: sales@newportuk.co.uk

Newport Electronics spol s.r.o.
Fryštátska 184, 733 01 Karviná • Czech Republic
TEL: +420 59 6311899 • FAX: +420 59 6311114
Toll Free: 0800-1-66342 • www.newport.cz • e-mail: info@newport.cz

Newport Electronics GmbH
Daimlerstrasse 26 • D-75392 Deckenpfronn • Germany
TEL: 49 7056 9398-0 • FAX: 49 7056 9398-29
Toll Free: 0800 / 6397678 • www.newport.de • e-mail: sales@newport.de

Mexico and Latin America
FAX: 001 (203) 359-7807
En Español: 001 (203) 359-7803

NEWPORTnet™ On-Line Service **Internet e-mail**
www.newportUS.com info@newportUS.com

NEWPORT Electronics, Inc.