

Step 16. Display the Decimal Point position
Press **↵** again to display the flashing Decimal Point position.

Step 17. Select the Decimal Point position
Press **↵** to select **FFF.F** Decimal Point position.

Step 18. Store selected Decimal Point position
By pressing **↵** momentarily the Decimal Point position will be stored and the instrument will go to the next menu item.

Step 19. Enter to Temperature Unit Submenu
Display shows **TEMP** Temperature Unit.

Step 20. Display available Temperature Units
Press **↵** to display the flashing Degree **F** or **C**.

Step 21. Scroll through Temperature Units selection
Press **↵** to select **F** Degree.

Step 22. Store the Temperature Unit
Press **↵** to display momentarily that the Degree Unit has been stored and the instrument will go automatically to the next menu item.

Step 23. Enter the Filter Constant Submenu
Display shows **FLER** Filter Constant Submenu.

Step 24. Display the Filter Constant Value Submenu
Press **↵** to display the flashing, previously selected Filter Constant.

Step 25. Scroll through available Filter Constants
Press **↵** to sequence thru Filter Constants **0001**, **0002**, **0004**, **0008**, **0016**, **0032**, **0064** and **0128**.

Step 26. Store the Filter Constant
Press **↵** momentarily to store **0004** Filter Constant and the instrument will automatically go to the next menu item.

Step 27. Enter Alarm 1 Menu
The display will show **ALR1** the top menu for Alarm 1. In the following steps we are going to enable Alarm 1, Deviation, Unlatch, Normally Open, Active Above, Enable at power on and +2°F High Alarm i.e. Process Value > Setpoint 1 Value +2°F will activate Alarm 1.

Step 28. Enter Alarm 1 Enable/Disable Submenu
Press **↵** to display flashing **ASBL** **ENBL**.

Step 29. Enable Alarm 1 Submenu
If flashing **ENBL** is displayed, press **↵**, if **ASBL** is displayed, press **↵** until **ENBL** is displayed, then press **↵** to store and go to the next menu item.

Step 30. Select the Deviation Control Type Submenu
Press **↵**. If flashing **DEV** Deviation is displayed press **↵**, otherwise press **↵** until flashing **DEV** is shown. Now press **↵** to store and go to next menu item.

Step 31. Select the Latched Type Submenu
Press **↵**. If flashing **UNLE** Unlatched is displayed press **↵**, otherwise press **↵** until **UNLE** is displayed. Press **↵** to store and advance to next menu item.

Step 32. Select the Normally Open Type of Contact Closure Submenu
Press **↵**. If flashing **NO** Normally Open is displayed, press **↵**, otherwise press **↵** until **NO** is displayed. Press **↵** to store and advance to next menu item.

Step 33. Select the Above Type of Active Submenu
Press **↵**. If flashing **ABOV** Above is displayed, press **↵**, otherwise press **↵** until **ABOV** is displayed. Press **↵** to store and advance to next menu item.

Step 34. Enable Alarm 1 at Power On (A.P.O.N)
Press **↵**. If flashing **ENBL** is displayed, press **↵**, otherwise press **↵** until **ENBL** is displayed. Press **↵** to store and advance to next menu item.

Step 35. Enter Alarm 1 High Submenu
Press **↵** twice to skip **ALRL** Alarm 1 Low value. **ALRL** is for below & **ALRH** for above.

Step 36. Set the Alarm 1 High value (ALRH)
Press **↵**. Press **↵** or **↵** until value to set the display to **002.0**. Press **↵** to save.

Step 37. Enter the Alarm 2 Menu
The display will show **ALR2** the top menu for Alarm 2. Repeat steps from 28 to 36 to set for Alarm 2 the same conditions as for Alarm 1.

Step 38. Configuration of Display Color Selection
Press **↵** until the **COLR** Display Color Selection Menu appears on the Display. Configure **COLR** as **GN** / **GRN** (green), **RD** / **RED** (red), **AM** / **AMBR** (amber). Please refer to the operator's manual if needed.

Note For color change on Setpoints refer to Owners Manual Section 2.

Step 39. Run a Test
Press **↵** until reset the controller and return to **RUN** Mode to display **075.0** (Ambient Temperature). Now you are ready to observe temperature as it rises 10°F higher than displayed. Touch the tip of the Thermocouple to raise the temperature above the Alarm 2 High value **082.0**, and AL2 will turn on, and Display Color will change from Green to Amber. Continue touching the tip to raise the temperature above the Alarm 1 High value **087.0** and Display Color will change from Amber to Red.

SPECIFICATION

Accuracy:
±0.5°C temp;
0.03% rdg. process typical

Resolution:
1°/0.1°; 10 µV process

Temperature Stability:
0.04°C/°C RTD;
0.05°C/°C TC @ 25°C (77°F);
50 ppm/°C process

Display:
4-digit, 7-segment LED,
57.2 mm (2.25")
with red, green, and amber
programmable colors for
process variable, set point
and temperature units.

Input Types:
Thermocouple, RTD, Analog
Voltage and Current

TC: (ITS 90)
J, K, T, E, R, S, B, C, N, L

RTD: (ITS 68)
100/500/1000 ohm Pt sensor
2-, 3-, or 4-wire; 0.00385 or
0.00392 curve

Voltage:
0 to 100 mV, 0 to 1 V, 0 to
10 Vdc

Current:
0 to 20 mA (4 to 20 mA)

Options: Communication
RS-232 / RS-485

Power:
100-240 Vac ±10%,
50-60 Hz, **22.5 W**

Dimensions:
289 L x 137 W x 73 D mm
(11.75" L x 5.375" W
x 2.875" D)

Panel Cutout:
279.4 L x 116.8 W mm
(11.00" L x 4.60" W)

Weight:
1,360 g (3 lbs)

Approvals:
CE per EN50081-1,
EN50082-2, EN61010-1

WARNING: These products are not designed for use in, and should not be used for, patient-connected applications.

This device is marked with the international caution symbol. It is important to read the Setup Guide before installing or commissioning this device, as the guide contains important information relating to safety and EMC.

It is the policy of NEWPORT to comply with all worldwide safety and EMC/EMI regulations that apply. NEWPORT is constantly pursuing certification of its products to the European New Approach Directives. NEWPORT will add the CE mark to every appropriate device upon certification.

The information contained in this document is believed to be correct, but NEWPORT Electronics, Inc. accepts no liability for any errors it contains, and reserves the right to alter specifications without notice.

TRADEMARK NOTICE:

NEWPORT, **NEWPORT**, and **newportUS.com** are trademarks of NEWPORT Electronics, Inc.

WARRANTY/DISCLAIMER

NEWPORT Electronics, Inc. warrants this unit to be free of defects in materials and workmanship for a period of one (1) year from the date of purchase. In addition to NEWPORT's standard warranty period, NEWPORT Electronics will extend the warranty period for four (4) additional years if the warranty card enclosed with each instrument is returned to NEWPORT.

If the unit malfunctions, it must be returned to the factory for evaluation. NEWPORT's Customer Service Department will issue an Authorized Return (AR) number immediately upon phone or written request. Upon examination by NEWPORT, if the unit is found to be defective, it will be repaired or replaced at no charge. NEWPORT's WARRANTY does not apply to defects resulting from any action of the purchaser, including but not limited to mishandling, improper interfacing, operation outside of design limits, improper repair, or unauthorized modification. This WARRANTY is VOID if the unit shows evidence of having been tampered with or shows evidence of having been damaged as a result of excessive corrosion; or current, heat, moisture or vibration; improper specification; misapplication; misuse or other operating conditions outside of NEWPORT's control. Components which wear are not warranted, including but not limited to contact points, fuses, and triacs.

NEWPORT is pleased to offer suggestions on the use of its various products. However, NEWPORT neither assumes responsibility for any omissions or errors nor assumes liability for any damages that result from the use of its products in accordance with information provided by NEWPORT, either verbal or written. NEWPORT warrants only that the parts manufactured by it will be as specified and free of defects.

NEWPORT MAKES NO OTHER WARRANTIES OR REPRESENTATIONS OF ANY KIND WHATSOEVER, EXPRESS OR IMPLIED, EXCEPT THAT OF TITLE, AND ALL IMPLIED WARRANTIES INCLUDING ANY WARRANTY OF MERCHANTABILITY AND FITNESS FOR A PARTICULAR PURPOSE ARE HEREBY DISCLAIMED.

LIMITATION OF LIABILITY: The remedies of purchaser set forth herein are exclusive, and the total liability of NEWPORT or otherwise, shall not exceed the purchase price of the component upon which liability is based. In no event shall NEWPORT be liable for consequential, incidental or special damages.

CONDITIONS: Equipment sold by NEWPORT is not intended to be used, nor shall it be used: (1) as a "Basic Component" under 10 CFR 21 (NRC), used in or with any nuclear installation or activity; or (2) in medical applications or used on humans. Should any Product(s) be used in or with any nuclear installation or activity, medical application, or used on humans, or misused in any way, NEWPORT assumes no responsibility as set forth in our basic WARRANTY/DISCLAIMER language, and, additionally purchaser will indemnify NEWPORT and hold NEWPORT harmless from any liability or damage whatsoever arising out of the use of the Product(s) in such a manner.

RETURN REQUEST/INQUIRIES

Direct all warranty and repair requests/inquiries to the NEWPORT Customer Service Department. BEFORE RETURNING ANY PRODUCT(S) TO NEWPORT, PURCHASER MUST OBTAIN AN AUTHORIZED RETURN (AR) NUMBER FROM NEWPORT'S CUSTOMER SERVICE DEPARTMENT (IN ORDER TO AVOID PROCESSING DELAYS). The assigned AR number should then be marked on the outside of the return package and on any correspondence.

The purchaser is responsible for shipping charges, freight, insurance and proper packaging to prevent breakage in transit.

FOR WARRANTY RETURNS, please consult NEWPORT for current repair BEFORE contacting NEWPORT:

1. Purchase Order number under which the product was PURCHASED.
2. Model and serial number of the product under warranty, and
3. Repair instructions and/or specific problems relative to the product.

FOR NON-WARRANTY REPAIRS, have the following information available BEFORE contacting NEWPORT:

1. Purchase Order number to cover the COST the repair,
2. Model and serial number of product, and
3. Repair instructions and/or specific problems relative to the product.

NEWPORT's policy is to make running changes, not model changes, whenever an improvement is possible. This affords our customers the latest in technology and engineering.

© Copyright 2002 NEWPORT Electronics, Inc. All rights reserved.

This document may not be copied, photocopied, reproduced, translated, or reduced to any electronic medium or machine-readable form, in whole or in part, without the prior written consent of NEWPORT Electronics, Inc.

PATENT NOTICE: This product is covered by one or more of the following patents: U.S. Pat. No. Des. 336,895; 5,274,577; 6,243,021/ Canada 2052599; 2052600/ Italy 1249456; 1250939/ France Brevet No. 91 12756/ Spain 2039150; 2048066/ UK Patent No. GB2 249 837; GB2 248 954/ Germany DE 41 34398 C2.  is a Trademark of OMEGA ENGINEERING, INC. USED UNDER LICENSE. Other U.S. and International patents pending or applied for.



iSeries Universal Temperature & Process Monitor

For immediate technical or application assistance please call:

1-800-6397678
1-800-NEWPORT

Newport Electronics, Inc.
2229 South Yale Street • Santa Ana, CA • 92704 • U.S.A.
TEL: (714) 540-4914 • FAX: (203) 968-7311
Toll Free: 1-800-639-7678 • <http://www.newportUS.com> • e-mail: info@newportUS.com
ISO 9001 Certified

Newport Technologies, Inc.
976 Bergar • Laval (Quebec) • H7L 5A1 • Canada
TEL: (514) 335-3183 • FAX: (514) 856-6886
Toll Free: 1-800-639-7678 • <http://www.newport.ca> • e-mail: sales@newport.ca

Newport Electronics, Ltd.
One Omega Drive • River Bend Technology Centre
Northbank, Irlam • Manchester M44 5BD • United Kingdom
Tel: +44 161 777 6611 • FAX: +44 161 777 6622
Toll Free: 0800 488 488 • <http://www.newportuk.co.uk> • e-mail: sales@newportuk.co.uk

Newport Electronics B.V.
Postbus 8034 • 1180 LA Amstelveen • The Netherlands
TEL: +31 20 3472121 • FAX: +31 20 6434643
Toll Free: 0800 0993344 • <http://www.newport.nl> • e-mail: sales@newport.nl

Newport Electronics spol s.r.o.
Rudé armády 1868, 733 01 Karviná 8 • Czech Republic
TEL: +420 69 6311899 • FAX: +420 69 6311114
Toll Free: 0800-1-66342 • <http://www.newport.cz> • e-mail: sales@newport.cz

Newport Electronics GmbH
Daimlerstrasse 26 • D-75392 Deckenpfronn • Germany
TEL: 49 7056 9398-0 • FAX: 49 7056 9398-29
Toll Free: 0800 / 6397678 • <http://www.newport.de> • e-mail: sales@newport.de

Newport Electronique S.A.R.L.
11, rue Jacques Cartier • 78280 Guyancourt • France
TEL: +33 1 61 37 29 00 • FAX: +33 1 30 57 54 27
Toll Free: 0800 466 342 • <http://www.newport.fr> • e-mail: sales@newport.fr

Mexico and Latin America
TEL: 001-800-826-6342 • FAX: 001 (203) 359-7807
En Español: 001 (203) 359-7803

NEWPORTnet™ On-Line Service www.newportUS.com
Internet e-mail info@newportUS.com

NEWPORT Electronics, Inc.



This Quick Start Reference provides information on setting up your instrument for basic operation. The latest complete Communication and Operational Manual as well as free Software and ActiveX Controls are available at www.newportUS.com or on the CD-ROM enclosed with your shipment.

SAFETY CONSIDERATION



This device is marked with the international Caution symbol.

The instrument is a panel mount device protected in accordance with Class II of EN61010-1. Remember that the unit has no power-on switch. Building installation should include a switch or circuit-breaker that must be compliant to IEC 947-1 and 947-3.

SAFETY:

- Do not exceed voltage rating on the label located on the back of the instrument housing.
- Always disconnect power before changing signal and power connections.
- Do not use this instrument on a work bench without its case for safety reasons.
- Do not operate this instrument in flammable or explosive atmospheres.

EMC:

- Whenever EMC is an issue, always use shielded cables.
- Never run signal and power wires in the same conduit.
- Use signal wire connections with twisted-pair cables.
- Install Ferrite Bead(s) on signal wire close to the instrument if EMC problems persist.

MOUNTING

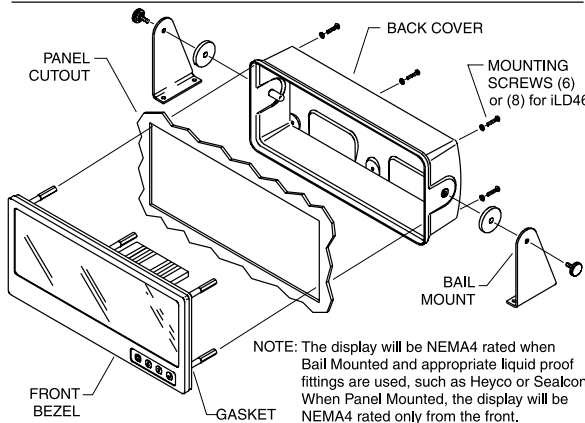
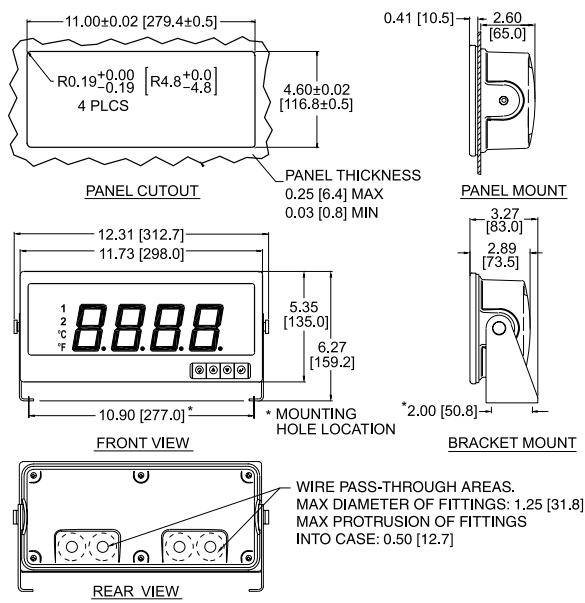

Mounting Big Display Through Panel:

- Using the panel cutout diagram shown above, cut an opening in the panel.
- Remove six screws at the back of Big Display to remove back cover.
- Insert the unit into the opening from the front of the panel, so the gasket seals between the bezel and the front of the panel.
- Align back cover to Big Display and reinstall screws.

Mounting Big Display on Bail:

- Use the Big Display template to mark the location of mounting screws on the flat surface.
- Be sure to leave enough room around the bail (as noted on the template drawing) to allow for removal and rotation of the display.
- The display can be rotated for the best viewing angle.

Disassembly Instruction:



Warning: Disconnect all ac power from the unit before proceeding.

- Remove all wiring connections from the rear of the instrument, by unscrewing the power and input connectors.
- Remove six screws at the back of the display and back cover.
- Remove the Big Display from the panel.
- To remove the Big Display from the bail, unscrew the two knobs at each end of the mounting brackets.

WIRING

Wire the instrument according to the figure shown below.



Warning: Do not connect ac power to your device until you have completed all input and output connections. This device must only be installed by a specially trained electrician with corresponding qualifications. Failure to follow all instructions and warnings may result in injury!

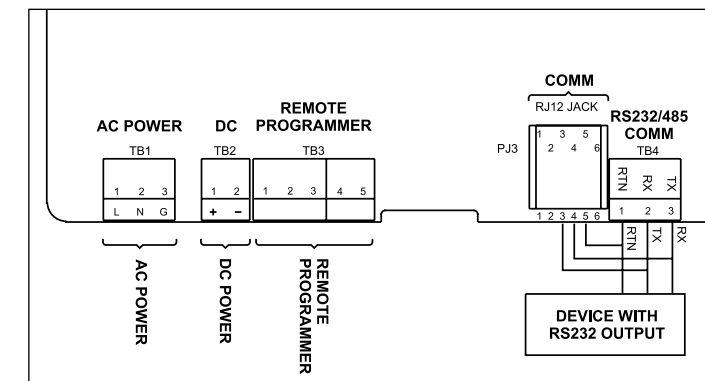

Connect the main power connections as shown in the figure below.

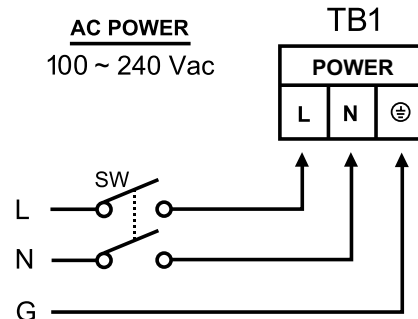

CONFIGURATION

MENU Mode:

Flashing display in MENU Mode means you can make your selection by pressing **▲** button. If the flashing display is not a four digit value, pressing **▼** button will always direct the instrument one step backward of the top menu item. The second push on the **▼** button will reset the instrument except after the setpoint and the alarms, that will go to the RUN Mode without resetting the instrument. The **▶** button will always sequence the instrument thru the menu items.

The **▶** button has two functions:

- To save a selected flashing display
- To direct the instrument to the next submenu level

RUN Mode:

- ▶** causes the display to flash the PEAK with the corresponding value. Press again to go back to RUN Mode.
- ▼** causes the display to flash VALLEY with the corresponding value. Press again to go back to RUN Mode.
- ▶** causes flashing PEAK or VALLEY to reset corresponding values. Pressing **▶** twice will cause the display to flash **5tRd** and put the instrument into standby, which disables all outputs and alarms. Press **▶** one more time to go back to RUN Mode.

OPERATION - (For Thermocouple Input)

Step 1. Apply Power to the Instrument

When your device is first powered up it will display the ambient temperature (assume 75°F).

Step 2. Enter Setpoint 1 Menu

Press **▶** one time from run mode to get to **SP1** Setpoint 1.

Step 3. Enter the Setpoint 1 Value Submenu

Press **▶**. Display shows the previous selection of Setpoint 1.

Step 4. Change the Setpoint 1 Value

Press **▲** or **▼** until desired value is displayed.

Step 5. Store the Setpoint 1 Value

Set the Setpoint 1 to 10 degree higher than Process value (SP1 = 85) and press **▶** to store, display flashes **5tRd** message and advances to **SP2** Setpoint 2 Menu.

Step 6. Store the Setpoint 2 Value

Repeat steps 3 and 4. Set the Setpoint 2 to 5 degree higher than Process value (SP2 = 80) and press **▶** to store, display flashes **5tRd** message and advances to **CONF** Configuration Menu.

Step 7. Enter the Input Type Menu

Press **▶** to enter **INPT** Input Type Menu.

Step 8. Enter to the submenu items of Input Menu

Press **▶** to display Input: Process, RTD or Thermocouple. If flashing **TC** is displayed press **▶** and proceed to Step 11.

Step 9. Scroll through available selection of Input Menu

Press **▲** until a flashing **TC** for Thermocouple is displayed.

FLOW CHART

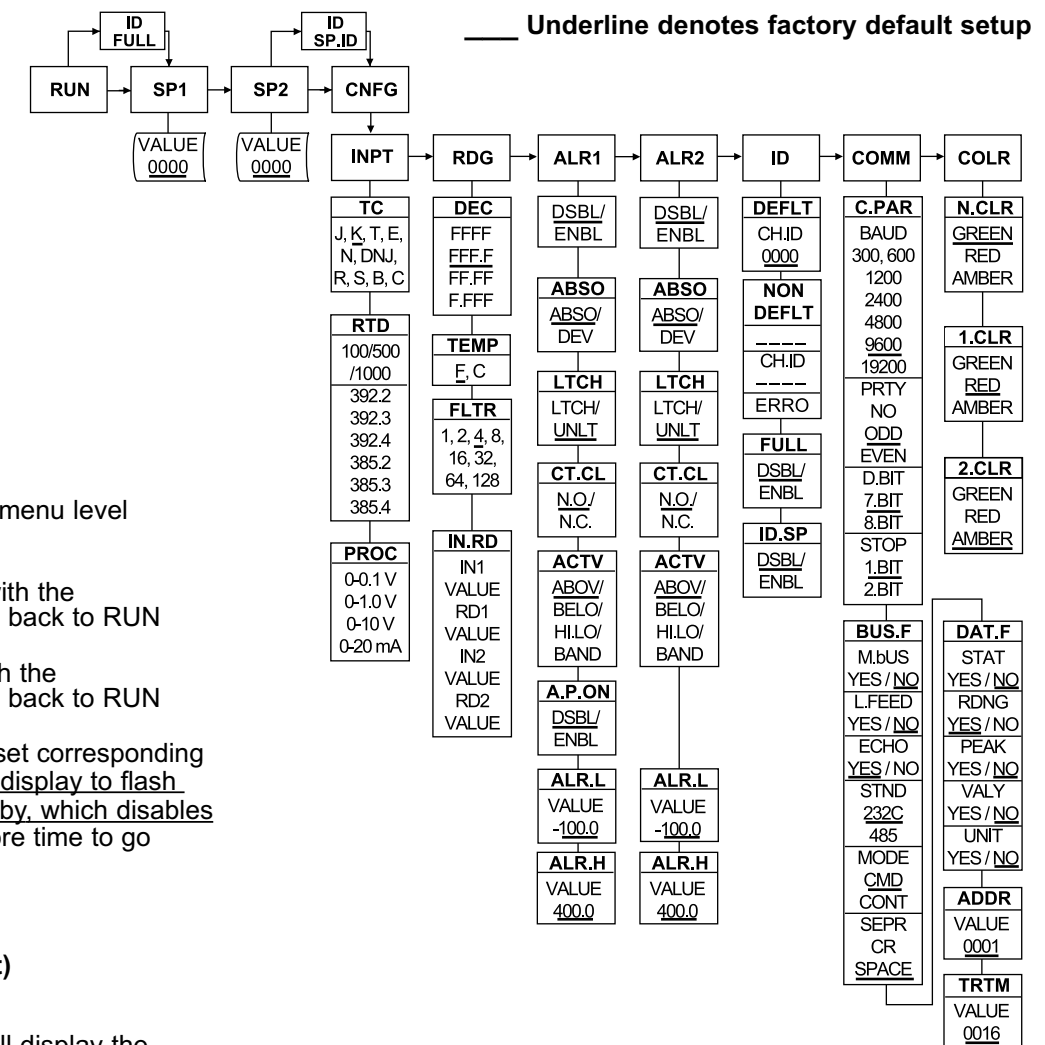

Step 10. Enter to the Thermocouple Input Submenu

Press **▶** to store Thermocouple Input. The display will stop flashing and show the top menu for Thermocouple types. If you press **▶** controller will step to next menu item (Skip to Step 14).

Step 11. Enter to the Thermocouple Type Input Submenu

Press **▶** to display flashing, previously selected Thermocouple type.

Step 12. Scroll through available selection of TC types

Press **▲** to sequence thru flashing Thermocouple types, (select k -for type "K" CHROMEGA®/ALOMEGA®)
 J K T E N DIN J R S B C - TC types
 J k t E N dN J R S b C - Display

Step 13. Store TC type

After you have selected the Thermocouple type press **▶** to store your selection, the instrument automatically advances to the next menu item.

Step 14. Enter to Reading Configuration Menu

The display shows **RDG** Reading Configuration, which is the top menu for 4 submenus: Decimal Point, Degree Units, Filter Constant and Input/Reading Submenus.

Step 15. Enter to Decimal Point Submenu

Press **▶** to show **DEC** Decimal Point.