

FLOW CHART

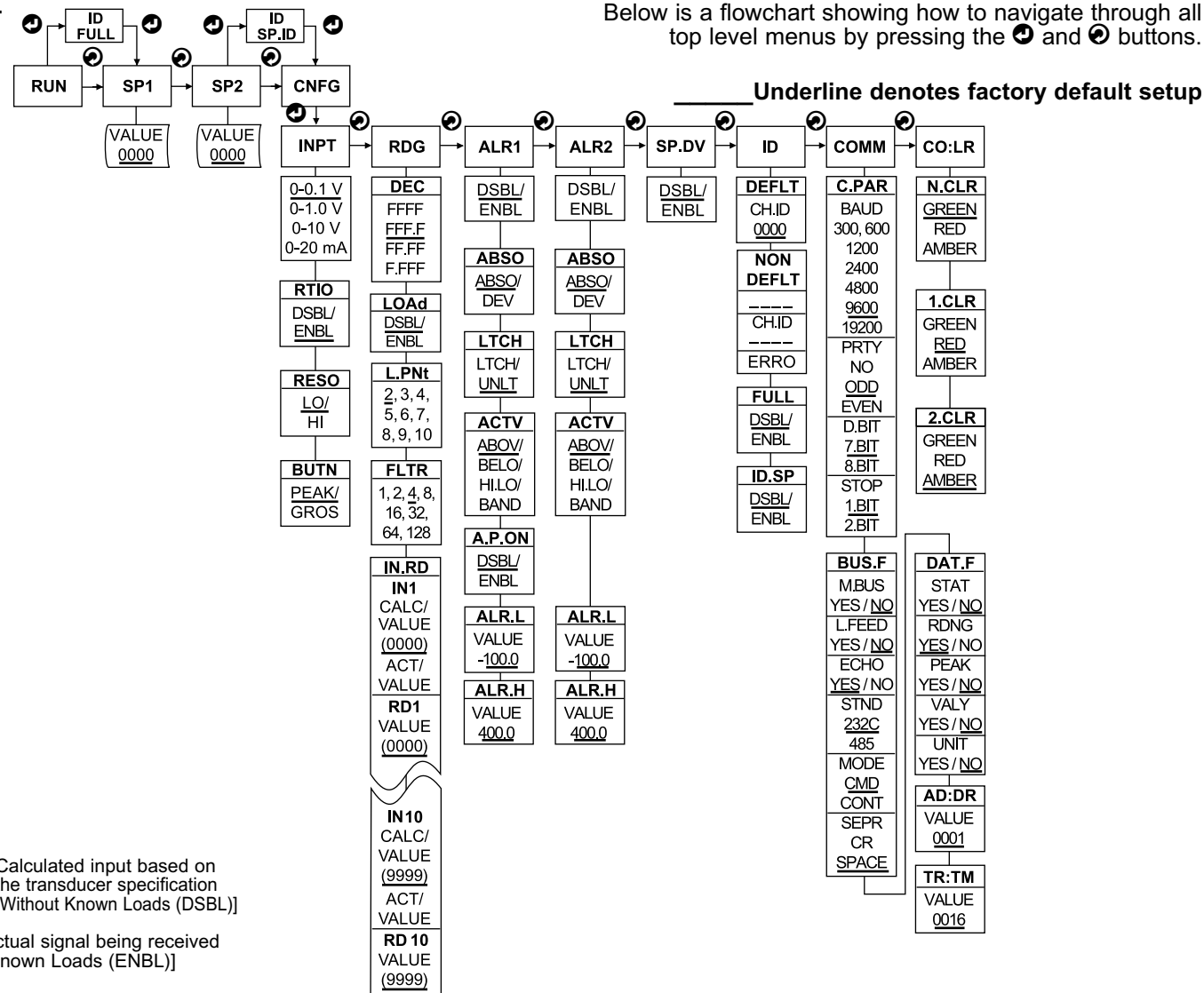

Below is a flowchart showing how to navigate through all top level menus by pressing the **↶** and **↷** buttons.

Underline denotes factory default setup

[†]Where:
CALC/VALUE = Calculated input based on the transducer specification [Without Known Loads (DSBL)]

ACT/VALUE = Actual signal being received [Known Loads (ENBL)]

READING CONFIGURATION SETUP (operation example)

Below is a flowchart showing how to navigate through the submenus of the Reading Configuration menu item by pressing the front buttons.

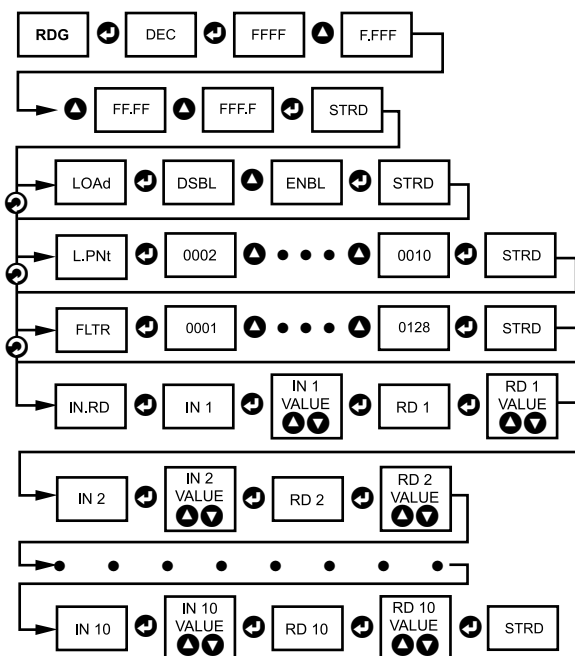

DISPLAY COLOR SETUP (examples)

Example 1:
Output 1 & Output 2: SSR
Alarm setup: Absolute, Above, Alarm 2 HI Value "ALR.H" =200, Alarm 1 HI Value "ALR.H"=400
Color Display setup: Normal Color "N.CLR"=Green, Alarm 1 Color "1.CLR"=Amber, Alarm 2 Color "2.CLR"=Red

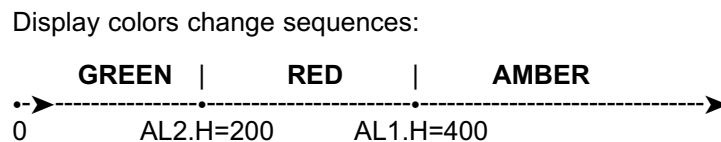

Example 2:
Output 1: Relay, Set Point 1 = 200,
Output 2: Relay, Set Point 2 = 200
Alarm 1 setup: Deviation, Band, "ALR.H" = 20
Alarm 2 setup: Deviation, Hi/Low, "ALR.H = 10", "ALR.L = 5"
Color Display setup: "N.CLR"=Green, "1.CLR"=Amber, "2.CLR"=Red

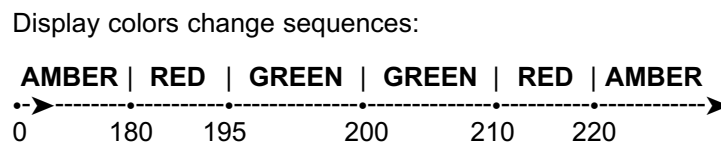

SPECIFICATION

- Accuracy:** 0.03% rdg.
 - Resolution:** 10 / 1 µV process
 - Linearization Points:** 10 points
 - Temperature Stability:** 50 ppm/°C process
 - Display:** 4-digit, 7-segment LED, 101.6mm (4.00") with red, green and amber programmable colors.
 - Input Types:** Analog Voltage and Current
 - Voltage:** 0 to 100 mV, 0 to 1 V (±100 mV), 0 to 10 Vdc
 - Input Impedance:** 10 MΩ for 100 mV, 1 MΩ for 1 or 10 Vdc
 - Current:** 0 to 20 mA (5 Ω load)
- Options: Communication**
RS-232 / RS-485 or
Excitation 5Vdc @40mA, 10Vdc @60mA
- Power Supply:**
100-240 Vac ±10%, 50/60 Hz, 22.5 W
- Operating Temperature:** 0 to 40°C
Storage Temperature: -20 to 60°C
Relative Humidity: 0 to 85%
- Protection:**
NEMA-4x (IP65)
- Dimensions:**
480.0 L x 210.8 W x 95.4 D mm (18.11" x 8.31" x 3.76")
- Panel Cutout:**
414.3 L x 179.4 W mm (16.31" L x 7.06" W)
- Weight:**
2,495 g (5.5 lbs)
- Approvals:**
CE per EN61010-1

WARNING: These products are not designed for use in, and should not be used for, patient-connected applications.

This device is marked with the international caution symbol. It is important to read the Setup Guide before installing or commissioning this device, as the guide contains important information relating to safety and EMC.

It is the policy of NEWPORT to comply with all worldwide safety and EMC/EMI regulations that apply. NEWPORT constantly pursuing certification of its products to the European New Approach Directives. NEWPORT will add the CE mark to every appropriate device upon certification.

The information contained in this document is believed to be correct, but NEWPORT Electronics, Inc. accepts no liability for any errors it contains, and reserves the right to alter specifications without notice.

TRADEMARK NOTICE:

NEWPORT, NEWPORT, and **newportUS.com** are trademarks of NEWPORT Electronics, Inc.

WARRANTY/DISCLAIMER

NEWPORT Electronics, Inc. warrants this unit to be free of defects in materials and workmanship for a period of **one (1) year** from the date of purchase. In addition to NEWPORT's standard warranty period, NEWPORT Electronics will extend the warranty period for **four (4) additional years** if the warranty card enclosed with each instrument is returned to NEWPORT.

If the unit malfunctions, it must be returned to the factory for evaluation. NEWPORT's Customer Service Department will issue an Authorized Return (AR) number immediately upon phone or written request. Upon examination by NEWPORT, if the unit is found to be defective, it will be repaired or replaced at no charge. NEWPORT's WARRANTY does not apply to defects resulting from any action of the purchaser, including but not limited to mishandling, improper interfacing, operation outside of design limits, improper repair, or unauthorized modification. This WARRANTY is VOID if the unit shows evidence of having been tampered with or shows evidence of having been damaged as a result of excessive corrosion; or current, heat, moisture or vibration; improper specification; misapplication; misuse or other operating conditions outside of NEWPORT's control. Components which wear are not warranted, including but not limited to contact points, fuses, and triacs.

NEWPORT is pleased to offer suggestions on the use of its various products. However, NEWPORT neither assumes responsibility for any omissions or errors nor assumes liability for any damages that result from the use of its products in accordance with information provided by NEWPORT, either verbal or written. NEWPORT warrants only that the parts manufactured by it will be as specified and free of defects.

NEWPORT MAKES NO OTHER WARRANTIES OR REPRESENTATIONS OF ANY KIND WHATSOEVER, EXPRESS OR IMPLIED, EXCEPT THAT OF TITLE, AND ALL IMPLIED WARRANTIES INCLUDING ANY WARRANTY OF MERCHANTABILITY AND FITNESS FOR A PARTICULAR PURPOSE ARE HEREBY DISCLAIMED.

LIMITATION OF LIABILITY: The remedies of purchaser set forth herein are exclusive, and the total liability of NEWPORT with respect to this order, whether based on contract, warranty, negligence, indemnification, strict liability or otherwise, shall not exceed the purchase price of the component upon which liability is based. In no event shall NEWPORT be liable for consequential, incidental or special damages.

CONDITIONS: Equipment sold by NEWPORT is not intended to be used, nor shall it be used: (1) as a "Basic Component" under 10 CFR 21 (NRC), used in or with any nuclear installation or activity; or (2) in medical applications or used on humans. Should any Product(s) be used in or with any nuclear installation or activity, medical application, or used on humans, or misused in any way, NEWPORT assumes no responsibility as set forth in our basic WARRANTY/DISCLAIMER language, and, additionally purchaser will indemnify NEWPORT and hold NEWPORT harmless from any liability or damage whatsoever arising out of the use of the Product(s) in such a manner.

RETURN REQUEST/INQUIRIES

Direct all warranty and repair requests/inquiries to the NEWPORT Customer Service Department. BEFORE RETURNING ANY PRODUCT(S) TO NEWPORT, PURCHASER MUST OBTAIN AN AUTHORIZED RETURN (AR) NUMBER FROM NEWPORT'S CUSTOMER SERVICE DEPARTMENT (IN ORDER TO AVOID PROCESSING DELAYS). The assigned AR number should then be marked on the outside of the return package and on any correspondence.

The purchaser is responsible for shipping charges, freight, insurance and proper packaging to prevent breakage in transit.

FOR WARRANTY RETURNS, please consult NEWPORT for current repair BEFORE contacting NEWPORT:

- 1. Purchase Order number under which the product was PURCHASED,
- 2. Model and serial number of the product under warranty, and
- 3. Repair instructions and/or specific problems relative to the product.

FOR NON-WARRANTY REPAIRS, have the following information available charges. Have the following information available BEFORE contacting NEWPORT:

- 1. Purchase Order number to cover the COST the repair,
- 2. Model and serial number of product, and
- 3. Repair instructions and/or specific problems relative to the product.

NEWPORT's policy is to make running changes, not model changes, whenever an improvement is possible. This affords our customers the latest in technology and engineering.

© Copyright 2002 NEWPORT Electronics, Inc. All rights reserved.

This document may not be copied, photocopied, reproduced, translated, or reduced to any electronic medium or machine-readable form, in whole or in part, without the prior written consent of NEWPORT Electronics, Inc.

PATENT NOTICE: This product is covered by one or more of the following patents: U.S. Pat. No. Des. 336,895; 5,274,577; 6,243,021/ Canada 2052599; 2052600/ Italy 1249456; 1250938/ France Brevet No. 91 12756/ Spain 2039150; 2048066/ UK Patent No. GB2 249 837; GB2 248 954/ Germany DE 41 34398 C2. is a Trademark of OMEGA ENGINEERING, INC. USED UNDER LICENSE. Other U.S. and International patents pending or applied for.

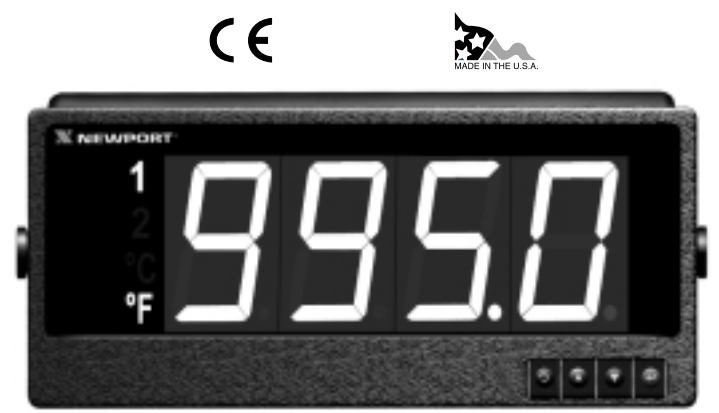

iSeries **iLD44-SP Big Display Universal Strain & Process Monitor**

For immediate technical or application assistance please call:

1-800-6397678
1-800-NEWPORT

Newport Electronics, Inc.
2229 South Yale Street • Santa Ana, CA • 92704 • U.S.A.
TEL: (714) 540-4914 • FAX: (203) 968-7311
Toll Free: 1-800-639-7678 • www.newportUS.com • e-mail:info@newportUS.com
ISO 9001 Certified

Newport Technologies, Inc.
976 Bergar • Laval (Quebec) • H7L 5A1 • Canada
TEL: (514) 335-3183 • FAX: (514) 856-6886
Toll Free: 1-800-639-7678 • www.newport.ca • e-mail:info@newport.ca

Newport Electronics, Ltd.
One Omega Drive • River Bend Technology Centre
Northbank, Irlam • Manchester M44 5BD • United Kingdom
Tel: +44 161 777 6611 • FAX: +44 161 777 6622
Toll Free: 0800 488 488 • www.newportuk.co.uk • e-mail:sales@newportuk.co.uk

Newport Electronics B.V.
Postbus 8034 • 1180 LA Amstelveen • The Netherlands
TEL: +31 20 3472121 • FAX: +31 20 6434643
Toll Free: 0800 0993344 • www.newport.nl • e-mail: info@newport.nl

Newport Electronics spol s.r.o.
Frystatska 184, 733 01 Karviná • Czech Republic
TEL: +420 59 6311899 • FAX: +420 59 6311114
Toll Free: 0800-1-66342 • www.newport.cz • e-mail: info@newport.cz

Newport Electronics GmbH
Daimlerstrasse 26 • D-75392 Deckenpfronn • Germany
TEL: 49 7056 9398-0 • FAX: +49 7056 9398-29
Toll Free: 0800 / 6397678 • www.newport.de • e-mail: sales@newport.de

Newport Electronique S.A.R.L.
11, rue Jacques Cartier • 78280 Guyancourt • France
TEL: +33 1 61 37 29 00 • FAX: +33 1 30 57 54 27
Toll Free: 0800 466 342 • www.newport.fr • e-mail: sales@newport.fr

Mexico and Latin America
FAX: 001 (203) 359-7807
En Español: 001 (203) 359-7803

NEWPORTnet™ On-Line Service **Internet e-mail**
www.newportUS.com info@newportUS.com





This Quick Start Reference provides information on setting up your instrument for basic operation. The latest complete Communication and Operational Manual as well as free Software and ActiveX Controls are available at www.newportUS.com or on the CD-ROM enclosed with your shipment.

SAFETY CONSIDERATION



This device is marked with the international Caution symbol.

The instrument is a panel mount device protected in accordance with EN61010-1:2001. Remember that the unit has no power-on switch. Building installation should include a switch or circuit-breaker that must be compliant to IEC 947-1 and 947-3.

SAFETY:

- Do not exceed voltage rating on the label located on the back of the instrument housing.
- Always disconnect power before changing signal and power connections.
- Do not use this instrument on a work bench without its case for safety reasons.
- Do not operate this instrument in flammable or explosive atmospheres.

EMC:

- Whenever EMC is an issue, always use shielded cables.
- Never run signal and power wires in the same conduit.
- Use signal wire connections with twisted-pair cables.
- Install Ferrite Bead(s) on signal wire close to the instrument if EMC problems persist.

MOUNTING

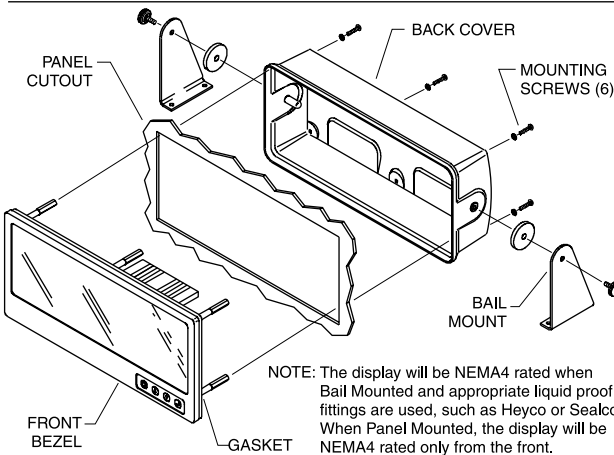
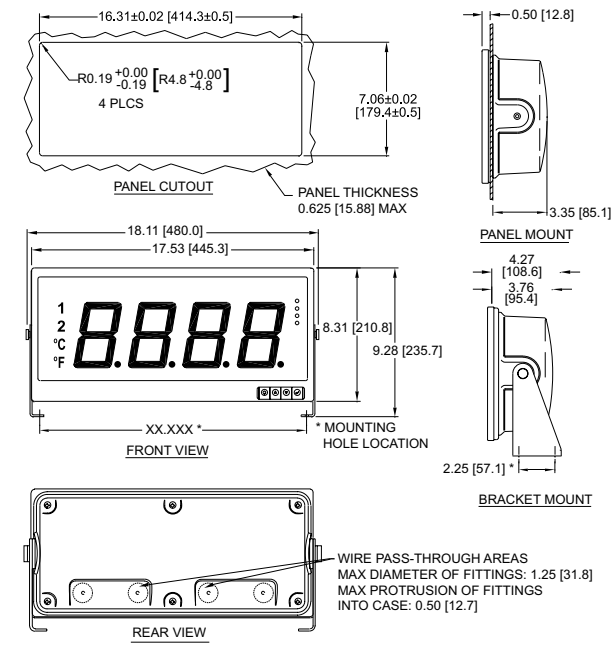

Mounting Big Display Through Panel:

- Using the panel cutout diagram shown above, cut an opening in the panel.
- Remove six screws at the back of Big Display to remove back cover.
- Insert the unit into the opening from the front of the panel, so the gasket seals between the bezel and the front of the panel.
- Align back cover to Big Display and reinstall screws.

Mounting Big Display on Bail:

- Mark the location of mounting screws on the flat surface.
- Be sure to leave enough room around the bail to allow for removal and rotation of the display.
- The display can be rotated for the best viewing angle.

Disassembly Instruction:



Warning: Disconnect all ac power from the unit before proceeding.

- Remove all wiring connections from the rear of the instrument, by unscrewing the power and input connectors.
- Remove six screws at the back of the display and back cover.
- Remove the Big Display from the panel.
- To remove the Big Display from the bail, unscrew the two knobs at each end of the mounting brackets.

WIRING

Wire the instrument according to the Input Wiring Connections described in your Operator's Manual.



Warning: Do not connect ac power to your device until you have completed all input and output connections. This device must only be installed by a specially trained electrician with corresponding qualifications. Failure to follow all instructions and warnings may result in injury!

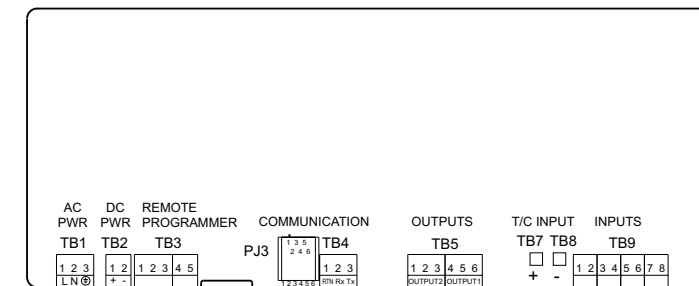

Connect the Main ac Power Connections as shown in the figure below.

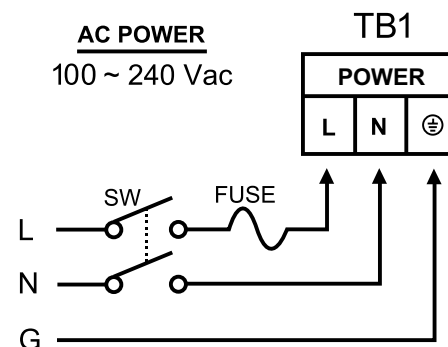

CONFIGURATION

MENU Mode:

Flashing display in MENU Mode means you can make your selection by pressing **⏏** button. If the flashing display is not a four digit value, pressing **⏏** button will always direct the instrument one step backward of the top menu item. The second push on the **⏏** button will reset the instrument except after the setpoint and the alarms, that will go to the RUN Mode without resetting the instrument. The **⏏** button will always sequence the instrument thru the menu items.

The **⏏** button has two functions:

- To save a selected flashing display
- To direct the instrument to the next submenu level

RUN Mode:

- ⏏** causes the display to flash the PEAK with the corresponding value. Press again to go back to RUN Mode.
- ⏏** causes the display to flash VALLEY with the corresponding value. Press again to go back to RUN Mode.
- ⏏** causes flashing PEAK or VALLEY to reset corresponding values. Pressing **⏏** twice will cause the display to flash **SEtBy** and put the instrument into standby, which disables all outputs and alarms. Press **⏏** one more time to go back to RUN Mode.

Button Functions in Configuration Mode

⏏ MENU	<ul style="list-style-type: none"> To enter the Menu, the user must first press ⏏ button. Use this button to advance/navigate to the next menu item. The user can navigate through all the top level menus by pressing ⏏. While a parameter is being modified, press ⏏ to escape without saving the parameter.
⏏ PK/GRS (UP)	<ul style="list-style-type: none"> Press the up ⏏ button to scroll through "flashing" selections. When a numerical value is displayed press this key to increase value of a parameter that is currently being modified. Holding the ⏏ button down for approximately 3 seconds will speed up the rate at which the setpoint value is incremented. In the Run Mode pressing ⏏ causes the display to flash the PEAK or GROSS value – press again to return to the Run Mode.
⏏ TARE (DOWN)	<ul style="list-style-type: none"> Press the down ⏏ button to go back to a previous Top Level Menu item. Press this button twice to reset the controller to the Run Mode. When a numerical value is flashing (except setpoint value) press ⏏ to scroll digits from left to right allowing the user to select the desired digit to modify. When a setpoint value is displayed press ⏏ to decrease value of a setpoint that is currently being modified. Holding the ⏏ button down for approximately 3 seconds will speed up the rate at which the setpoint value is decremented. In the Run Mode pressing ⏏ causes the display to flash TARE value to tare your reading (zeroing).
⏏ ENTER	<ul style="list-style-type: none"> Press the enter ⏏ button to access the submenus from a Top Level Menu item. Press ⏏ to store a submenu selection or after entering a value — the display will flash a SEtBy message to confirm your selection. To reset flashing PEAK or GROSS press ⏏. In the Run Mode, press ⏏ twice to enable Standby Mode with flashing SEtBy.



Reset: Except for Alarms, modifying any settings of the menu configuration will reset the meter prior to resuming Run Mode.

DISPLAY ABBREVIATIONS

SP1	Set Point 1 Value	SP2	Set Point 2 Value
CNFG	Configuration Menu	INPt	Input Type (Range)
INPt	Input Type (range)	0 - 0.1	100 mV Input Voltage
0 - 1.0	1 V Input Voltage	0 - 10	10 V Input Voltage
0 - 20	20 mA Input Current	RESO	Display Resolution
Rtio	Ratiometric Operation	PEAK	Peak Value
bUtN	Button Peak/Gross		
GROS	Gross Value		
RdG	Reading Configuration		
dEC	Decimal Point	F.FFF	Decimal Point Position
		..FFF	Decimal Point Position
LOAd	Input Load	EnbL	Scaling with Known Loads (Actual Value)
DSbL	Scaling without Known Loads (Calculated Value)	L.PNt	Linearization Points
0002..	Number of Linearization Points	FLtR	Filter Constant
..0010	Filter Constant Value	IN.Rd	Input/Reading Scale and Offset Menu
0001..	Filter Constant Value	Rd 1	Reading 1
..0128		Rd 2	Reading 2
IN 1	Input 1
IN 2	Input 2
....
IN 10	Input 10	Rd 10	Reading 10
ALR1	Alarm 1 Menu	AbSo	Absolute Mode
dEV	Deviation Mode	Ltch	Latched Mode
UNLt	Unlatched Mode	Ct.CL	Contact Closure
N.o.	Normally Open	N.c.	Normally Closed
ActV	Active Type	AboV	Active Above
bELo	Active Below	Hi.Lo	Above High/Below Low
bANd	Above or Below Band	A.P.oN	AlarmEnable/Disable at Power On
ALR.L	Alarm Low Value	ALR.H	Alarm High Value
ALR.2	Alarm 2 Menu		
SP.dN	Set Point Deviation	CH.Id	Change ID Code
Id	ID Code Menu	SP.Id	Set Point ID
FULL	Full ID	NONE	Communication is Not Installed
COMM	Communication Option*	bAUd	Baud Rate
C.PAR	Communication Parameters	odd	Odd
PrtY	Parity	No	No
EVEN	Even	7.bit	7 Data Bit
dAtA	Data Bit	StOP	Stop Bit
8.bit	8 Data Bit	2.bit	2 Stop Bit
1.bit	1 Data Bit	M.bus	Modbus Protocol
bus.F	Bus Format	ECHO	Echo
LF	Line Feed	232C	RS-232
StNd	Communication Standard	ModE	Data Flow Mode
485	RS-485	CoNt	Continuous Mode
CMd	Command Mode	SPCE	Space
SEPR	Data Separation Character	dAt.F	Data Format
cR	Carriage Return	RdNG	Transmit Reading Value
stAt	Alarm Status	GROS	Transmit Gross Value
PEAk	Transmit Peak Value	AddR	Transmit Multipoint Address
UNIT	Units of Measurement		
tR.tM	Transmit Color Selection	N.CLR	Normal Color Display
COLR	Display Color Selection	2.CLR	Alarm2 Color Display
1.CLR	Alarm 1 Color Display	AMbR	Display Color is Amber
REd	Display Color is Red		
GRN	Display Color is Green		
dSbL	Disable	ENbL	Enable
ERRO	Error	+ OL	Input (+) Overload

* For abbreviations of Communication Option see Communication Manual.