

**Temperature, Process,
 Strain Meters & PID Controllers**



\$240
 1/8 DIN meter
\$310
 with 2 control outputs



- ✓ High Quality
- ✓ 5-Year Warranty
- ✓ High Accuracy $\pm 0.5^{\circ}\text{C}$ (0.9°F), 0.03% Reading
- ✓ User-friendly, Simple to Configure
- ✓ Free Software
- ✓ Full Autotune PID Control
- ✓ Universal Inputs: Thermocouple, RTD, Process Voltage/Current, Strain
- ✓ Totally Programmable Color Displays, Standard
- ✓ Built-in Excitation, Standard
- ✓ 2 Control or Alarm Outputs, Choice of dc Pulse, Mechanical Relays, Analog Voltage and Current.

The NEWPORT® i8 is a 1/8 DIN size (96mm x 48mm) Digital Panel Meter featuring the big iSeries color-changing display. The digits are twice the size of typical 1/8 DIN panel meters. The iSeries meters feature the only LED displays that can be programmed to change color between Green, Amber, and Red at any set point or alarm point. The "i8" model is available as an extremely accurate programmable digital panel meter with no outputs or with dual outputs for controlling or alarming functions. Other options include isolated programmable analog output, serial communications, Modbus and Ethernet. The user can easily program the i8 for any control or alarming requirement from simple on-off to full autotune PID with a choice of Form C SPDT relays, Solid State Relays, DC pulse, and Analog (voltage and current) outputs.

Fully Isolated Analog Output for retransmission of the process value is available in addition to the control and alarm relays (specify model i8A33).

The i8 covers a broad selection of transducer and transmitter inputs with two input models:

The UNIVERSAL TEMPERATURE & PROCESS instrument (model "I") handles ten common types of thermocouples, multiple RTD's, and several Process (DC) Voltage and Current ranges. This model also features built-in excitation, 24 Vdc @ 25 mA. With it's wide choice of signal inputs, this model is an excellent choice for measuring or controlling temperature with a thermocouple, RTD, or 4-20mA transmitter.

The STRAIN & PROCESS instrument (model "IS") measures inputs from Load Cells, Pressure Transducers, and most any strain gauge sensor as well as Process Voltage and Current ranges.

The "iS" has built-in 5 or 10 Vdc excitation for bridge transducers, 5Vdc@ 40mA or 10 Vdc @ 60mA. (Any excitation voltage between 5 and 24 Vdc is available by special order.) This "iS" model supports 4 and 6 wire bridge configurations, ratiometric and non-ratiometric measurements. The "iS" features fast and easy "in process" calibration/scaling of the signal inputs to any engineering units. This model also features 10 Point Linearization which allows the user to linearize the signal input from extremely nonlinear transducers of all kinds. The NEWPORT® i8 1/8 DIN enclosure has a NEMA 4 (IP65) rated front bezel and removable rear connectors for easy installation and wiring.

	Input Type	Range	Accuracy
	Process Voltage	0 to 100 mV, 0 to 1 V, 0 to 10 Vdc	0.03% rdg
	Process Current	0 to 20 mA (4 to 20 mA)	0.03% rdg
J	Iron-Constantan	-210 to 760°C/-346 to 1400°F	0.4°C/0.7°F
K	CHROMEGA®-ALOMEGA®	-270 to -160°C/-160 to 1372°C -454 to -256°F/-256 to 2502°F	1.0°C/0.4°C 1.8°F/0.7°F
T	Copper-Constantan	-270 to -190°C/-190 to 400°C -454 to -310°F/-310 to 752°F	1.0°C/0.4°C 1.8°F/0.7°F
E	CHROMEGA®-Constantan	-270 to -220°C/-220 to 1000°C -454 to -364°F/-364 to 1832°F	1.0°C/0.4°C 1.8°F/0.7°F
R	Pt/13%Rh-Pt	-50 to 40°C/40 to 1768°C -58 to 104°F/104 to 3214°F	1.0°C/0.5°C 1.8°F/0.9°F
S	Pt/10%Rh-Pt	-50 to 100°C/100 to 1768°C -58 to 212°F/212 to 3214°F	1.0°C/0.5°C 1.8°F/0.9°F
B	30%Rh-Pt/6%Rh-Pt	100 to 640°C/640 to 1820°C 212 to 1184°F/1184 to 3308°F	1.0°C/0.5°C 1.8°F/0.9°F
C	5%Re-W/26%Re-W	0 to 2320°C/32 to 4208°F	0.4°C/0.7°F
N	Nicrosil-Nisil	-250 to -100°C/-100 to 1300°C -418 to -148°F/-148 to 2372°F	1.0°C/0.4°C 1.8°F/0.7°F
L	J DIN	-200 to 900°C/-328 to 1652°F	0.4°C/0.7°F
RTD	Pt, 0.00385, 100, 500, 1000 Ω	-200 to 900°C/-328 to 1652°F	0.4°C/0.7°F
RTD	Pt, 0.00392, 100, 500, 1000 Ω	-200 to 850°C/-328 to 1562°F	0.4°C/0.7°F

i/8

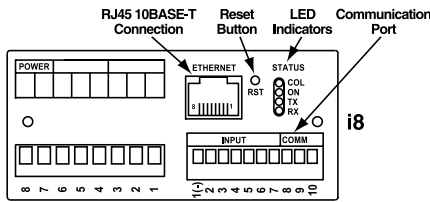
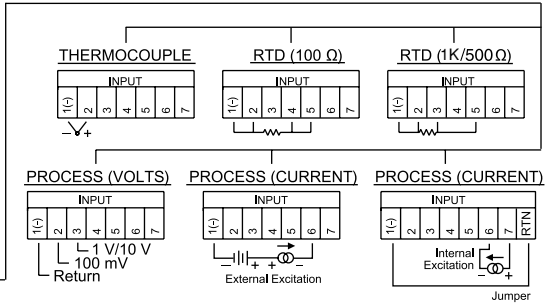
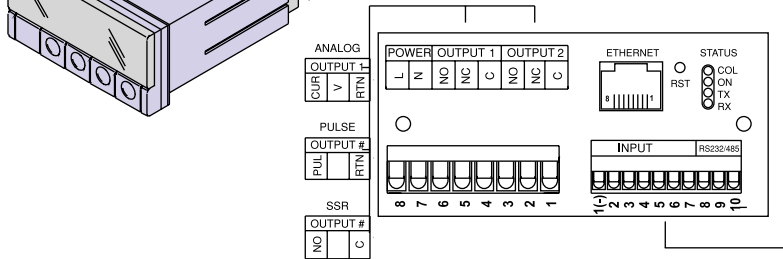
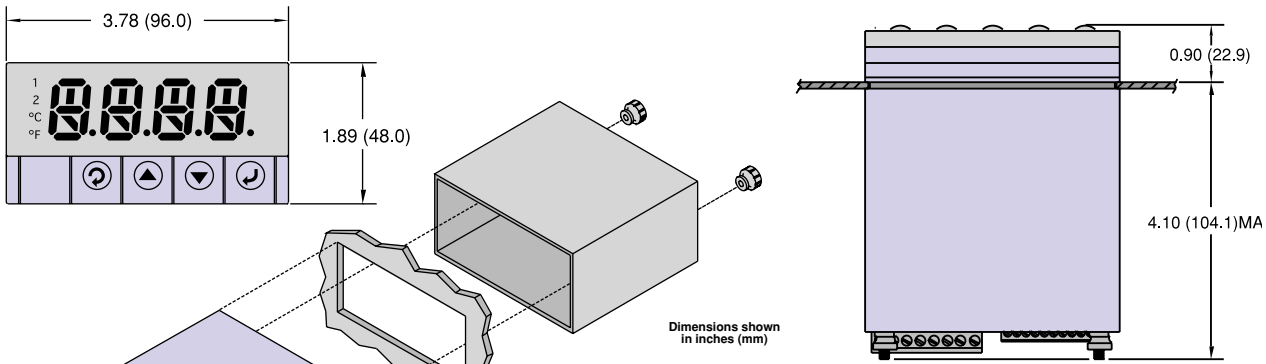

To Order (*Specify Model No.)

Model Number	Description	Price
i800	Temperature/Process (Monitor only) 1/8 DIN	240
i8A00	Temperature/Process Monitor with Isolated Analog Output 1/8 DIN *1	295
iS800	Strain/Process (Monitor only) 1/8 DIN	275

CONTROL OUTPUTS #1 & 2 Direct (Cool) or Reverse (Heat) Acting

i8	(*)	(*)	Temperature/Process with 2 Control Outputs	310
i8A	(*)	(*)	Temperature/Process with Isolated Analog Output and 2 Outputs*1,*4	365
iS8	(*)	(*)	Strain/Process with 2 Control Outputs	370
2	2		Two solid state relays (SSR's): 0.5 A @ 120/240 Vac continuous	N/C
2	3		SSR and relay: Form "C" SPDT 3 A @ 120 Vac, 3 A @ 240 Vac	
2	4		SSR and pulsed 10 Vdc @ 20 mA (for use with external SSR)	
3	3		2 Relays: Form "C" SPDT 3 A @ 120 Vac, 3 A @ 240 Vac	
4	2		Pulsed 10 Vdc @ 20 mA (for use with external SSR) and SSR	
4	3		Pulsed 10 Vdc @ 20 mA (for use with external SSR) and relay: Form "C" SPDT 3 A @ 120 Vac, 3 A @ 240 Vac	
4	4		Two pulsed 10 Vdc @ 20 mA (for use with external SSR)	
5	2		Analog Output selectable as either control or retransmission of process value; 0 to 10 Vdc or 0-20 mA @ 500 ohm max. and SSR	
5	3		Analog Output 0 to 10 Vdc or 0-20 mA @ 500 ohm max. and Relay	
5	4		Analog Output 0 to 10 Vdc or 0-20 mA @ 500 ohm max. and Pulse 10 Vdc	
			-AL Limit Alarm Version (Simplified Menu; No PID Control) ^{3, 4}	

NETWORK OPTIONS

Option	Description	Price
-EI	Ethernet with Embedded Internet	55
-C24	Isolated RS-232 and RS-485 300 to 19.2 k baud ²	60
-C4EI	Ethernet with Embedded Web Server + Isolated RS-485/422 hub for up to 31 devices ^{*1}	115

POWER SUPPLY

*	Standard power input: 90-240 Vac/dc, 50-400 Hz (no entry required)	N/C
-DC	12-36 Vdc, 24 Vac*2	25

FACTORY SETUP

-FS	Factory Setup and Configuration (req. -C24 Serial Communication option)	N/C
-----	---	-----

SOFTWARE (Requires Network Option)

Option	Description	Price
OPC-SERVER LICENSE	OPC Server/Driver Software License	295

*1 Analog Output (Option 5) and Ethernet Options are not available for the i8A controller.

*2 -DC, -C24, or -C4EI not available with excitation.

*3 Analog Output (Option 5) is not available with -AL units.

*4 For i8A** -AL: One Alarm and One Analog Retransmission.

ORDERING EXAMPLES: i8A00 is a 1/8 DIN Meter with isolated scalable analog retransmission of the process value \$295; i833-AL-C24 is a 1/8 DIN Indicator and Dual Alarm only with serial communication \$370.



Totally Programmable Color Displays

The NEWPORT® i/8, i/16, and i/32 are the first complete series of 1/8, 1/16 and 1/32 DIN process control instruments with totally programmable color displays. The display can be programmed to change color at any setpoint or alarm point.

